

Procédure d'installation

- (1) Séparez les caches (gauche et droit) de vos ampoules

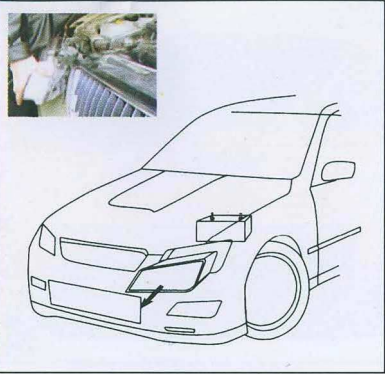

- (2) Retirez les ampoules halogène de vos caches

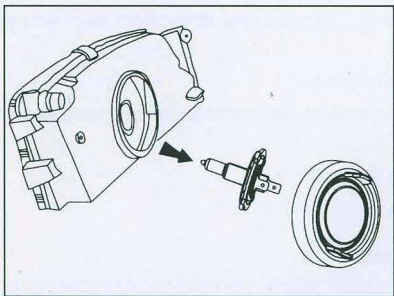

- (3) Faites un trou de 25mm de diamètre si besoin est dans le plastique de protection

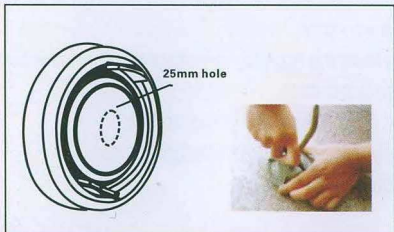

- (4) Enlevez le capot de protection de votre ampoule HID, puis glissez celle-ci dans l'optique.

Attention : NE PAS METTRE VOS DOIGTS SUR LA PARTIE EN VERRE DE L'AMPOULE

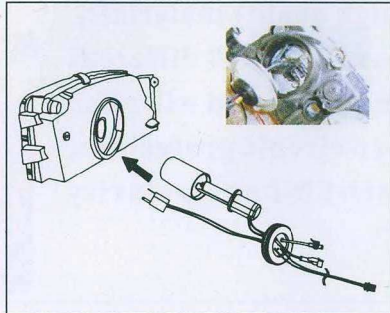

- (5) Refixez la protection étanche

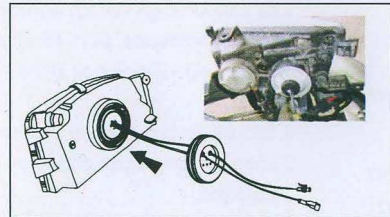

- (6) Connectez vos ballast sur les ampoules, puis fixez-les avec les vis, ou bien avec des colliers Rilsan ou du double-face (non fournis)

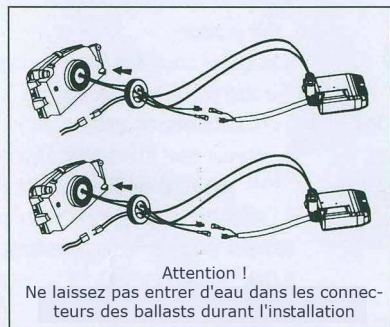

Process For Installation

* Installation du ampoule Bi Xenon

1. Faites pivoter la protection sur la gauche et oter-la.
Faites ensuite passer l'ampoule au travers du cache en plastique

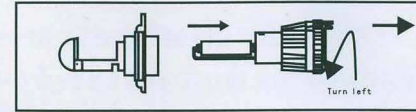

2. Placer le capot de l'ampoule sur l'optique. Une fois installé, placez y l'ampoule à l'intérieur, puis en tournant à droite de façon à la bloquer (LOCK)

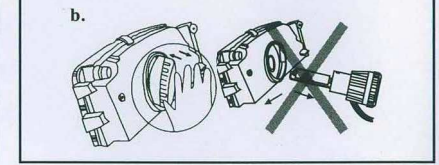
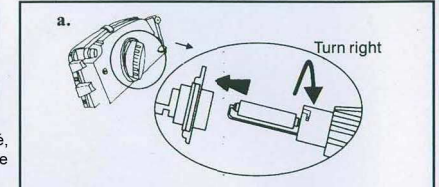
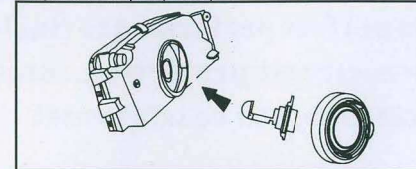

3. Veuillez suivre le diagramme ci-dessous, pour l'installation du relais

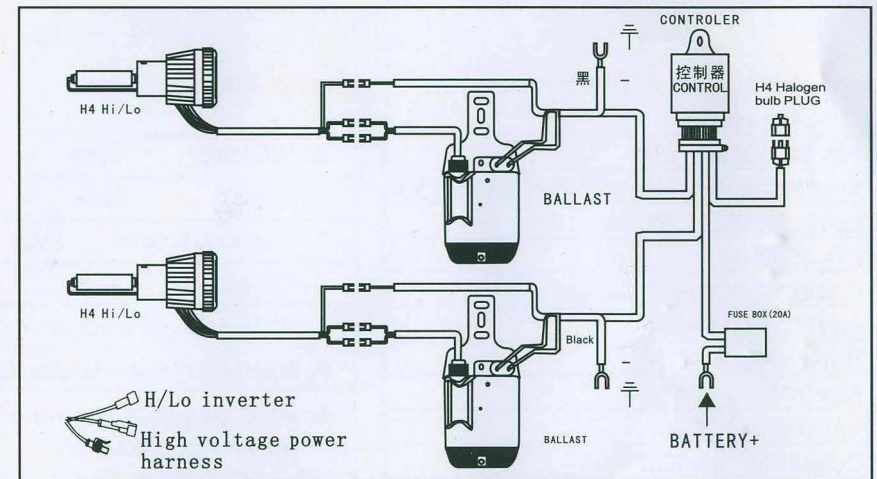

4. Une fois en place, vous pouvez y installer les vis (fournies) afin de fixer l'ensemble

